



Self-contained 12 Volt DC
Air Conditioner
Model SMB05ACP

Owner's Manual



Chapter 1: Safety Considerations 2

Chapter 2: Routine Maintenance 3

Chapter 3: General Description..... 5

Chapter 4: Thermostats and Controllers 6

Chapter 5: Winterizing the System 7

Chapter 6: Troubleshooting..... 8

Chapter 7: Wiring Diagram..... 10

Chapter 8: Spare Parts List 11

Chapter 8: Warranty 12

Manufactured By:

Marvair® Division of AIRXCEL®, Inc.
P.O. Box 400 • Cordele, Georgia 31010
156 Seedling Drive • Cordele, Georgia 31015
Ph: 229-273-3636 • Fax: 229-273-5154
Email: marvair@airxcel.com
www.marvair.com

Marvair Marine UK
Unit B8 • Arena Business Centre • Holyrood Close
Poole, Dorset BH17 7FL.
+44 1202 606405
www.marvair.co.uk

Part #01514 9/09-3
Supersedes 5/09-2

SMB Air Conditioner

Chapter 1 – Safety Considerations

Congratulations on your purchase of a marine air conditioner by Marvair®. Your air conditioner has been designed to provide years of safe, dependable operation. These instructions contain a general description on the operation of the unit, how set up thermostat, a list of routine maintenance items, basic trouble shooting information, and the warranty.

The first thing we recommend for you to do is to write down the serial number of the unit. The number can be found on the data label on the unit. Refer to them whenever you call upon your Marvair Marine dealer regarding this unit.

Model No. SMB05ACP **Serial Number** _____

Safety Considerations

This is the safety alert symbol . When you see this symbol on the Marvair Marine unit and in the instruction manuals be alert to the potential for personal injury. Understand the signal word DANGER, WARNING and CAUTION. These words are used to identify levels of the seriousness of the hazard.

 **DANGER** Failure to comply will result in death or severe personal injury and/or property damage.

 **WARNING** Failure to comply could result in death or severe personal injury and/or property damage.

 **CAUTION** Failure to comply could result in minor personal injury and/or property damage.

IMPORTANT is used to point out helpful suggestions that will result in improved installation, reliability or operation.

DANGER

Self-contained units or evaporators of split systems should never be installed in engine rooms or other areas where fuel, battery or bilge vapors may be introduced to the living quarters on board.

These components do not meet federal requirements for ignition protection. Do not install in spaces containing gasoline engines, tanks, LPG/CPG cylinders, valves, fuel line fittings, or regulators. Failure to comply may result in injury or death.

Do not terminate condensate drain line within four feet of any outlet of engine or generator exhaust systems, nor in a compartment housing an engine or generator.

Installation and servicing of this system can be hazardous due to system pressure and electrical components. When working on this equipment, always observe precautions described in the literature, tags and labels attached to the unit(s). Follow all safety codes.

Marvair recommends that you use only factory certified, EPA licensed refrigerant technicians and qualified marine electricians. ABYC certification in both HVAC and Marine electrical trades is desirable. In receiving these certifications, a technician and his employer has made a statement of commitment to professional, technically proficient and reliable service.

CAUTION

Certain components will run at fairly high temperatures. Exercise care in working around operating equipment. Do not touch operating machinery without the aid of qualified personnel, as referred to above.

SMB Air Conditioner

Chapter 2 - Routine Maintenance

Air Flow

Proper air flow is critical to the operation of the air conditioner. All grilles, both supply and return, must never be blocked by objects such as bed linens, duffel bags, tackle boxes, etc.

Return Air Grille(s) and Filter(s)

Return air grilles are available in both aluminum and wood in standard configurations. They do not have adjustable louvers and are available with and without filters. Return air filters should be cleaned regularly. The filter shipped with your unit is located in front of the air coil can be cleaned with a vacuum cleaner or rinsed with fresh water.

If your unit's return air grille has a filter, be sure that your boat builder or installation technician has removed the standard filter that comes with every unit in front of the evaporator (air) coil. Two filters can unduly restrict air flow and in some cases, cause problems with performance. Use EITHER a return air filter grille or the supplied filter, never both.

Depending upon the floor plan, your boat's space constraints may dictate that a unit be installed in an area that makes it difficult to access and clean the filter. If this is the case, and you do not have a return air filter grille, you should consider removing the disposable unit filter and upgrading to a return air filter grille.

NOTE: Blocking the return air grille or neglecting filter cleaning will result in a restriction of air flow. After a period of time, ice will form on the evaporator coil and a resultant LOW PRESSURE FAULT shutdown.

Supply Air Grille(s)

Some installations will have more than one supply air grille. Standard main supply air grilles are generally made of aluminum or wood frames with two or four-way adjustable louvers. These may be adjusted to direct air flow from the grille to ensure a uniform cabin temperature. Main supply air grilles should never be closed at any time while the unit is running. The secondary supply air grille more frequently will be a 4" (102mm) round plastic design, but they can also be of the aluminum or wood frame standard configuration and are usually located out of the main salon, galley, dinette area. These may, depending upon the style you or your boat manufacturer has chosen, be closable. During the day, it may be closed should you like more air directed to the main living area. Consult with your local Marvair Marine service representative if you are unsure which is the main supply grille on your boat. Closing off the main supply air grille or secondary air grille, in some applications, may restrict air flow and cause ice up of the evaporator in the cooling mode.

Condensate Pan and Lines

The condensate and lines can develop an algae type growth. Periodic inspection and treatment with a mild solution of bleach and water poured into the condensate pan will keep the condensate pan and lines clear.

Sea Water Strainer

The seawater strainer is available in several configurations – bronze or plastic. Yours has been sized in accordance to system specifications for volume of water required. It is used to prevent debris such as eelgrass, sea weed, leaves, etc., from passing through the system water lines and condensing coil. These items could lodge themselves in the water supply causing several possible shutdown faults, and left

SMB Air Conditioner

unchecked, equipment damage. Should the strainer become clogged or partially obstructed, adverse performance will be experienced. The first indication will be a reduction in the quantity of the discharge water. Eventually, the high pressure switch in the unit will activate and shut the unit down. (See Troubleshooting.) Turn the power off to the unit; check strainer and pump, restart. (See Pump and Troubleshooting.)

To eliminate these potential problems, it is recommended that you check to make sure you have water flow each time you turn the system on and clean your strainer weekly. More often as conditions dictate. In some regions, it is common to experience a tremendous presence of jellyfish or sea nettles concentrated in back bay marinas for short periods of time. These can clog strainers and water pumps every hour to hour and a half in some cases. In such severe conditions, seek the advice of your local factory service representative. They will be most familiar with solutions to localized situations. Marvair works closely with our servicing dealers when custom solutions are required. During the warranty period, factory approval must be obtained for any modification to be done to alleviate the problem without voiding warranty coverage.

Sea Water Pump

Your seawater pump has been sized in accordance with specifications for system water flow and volume. A minimum of 1.5 GPM (5.69 LPM) measured at the inlet to the air conditioner of water flow is required for proper operation. The pump is a self priming.

Occasionally, sea grass, jellyfish and other items may pass through your strainer and get lodged in the pump impeller. Should cleaning your strainer fail to eliminate a water flow problem, you should next check the pump. First loosen the discharge line and gently remove it from the pump assembly. (Make sure the seacock is open.) Water should rise above the pump to a level equal to the waterline of your boat. If not, there is a blockage.

SMB Air Conditioner

Chapter 3 - General Description

The 12 VDC air conditioner built by Marvair® are self-contained, water-cooled units designed for use with either fresh or seawater. The SMB models are designed to be used with a wall mounted thermostat and use R-134a refrigerant.

Operating Ranges

The air conditioner is designed to work over a wide range of conditions. Among the most important factors that affect the performance of the unit are inlet water temperature, inlet (return) air temperature and the humidity of the inlet (return) air. Please consult your Marvair Marine dealer or the factory if you have a question about the operation of your air conditioner.

Electrical

The SMB model is designed to operate of a nominal 12 volt DC power supply - an inverter is not required. The unit will operate on a DC voltage from 9 volts to 17 volts.

General Operation

The 12 VDC air conditioner uses R-134a refrigerant in a conventional vapor compression cycle to transfer heat from the air in the boat to the water. In the cooling mode, a blower blows the cabin air through the indoor or evaporator coil where it is cooled and dehumidified. Liquid refrigerant passing through the evaporator is boiled into a gas by heat removed from the air. The warmed refrigerant gas enters the compressor where its temperature and pressure are increased. The hot refrigerant gas travels to the water coil or condenser where it is cooled by the water and condenses to a liquid. Liquid refrigerant is metered back into the evaporator coil to repeat the process.

SMB Air Conditioner

Chapter 4 - Thermostats

Your unit is controlled by a wall mounted thermostat. Before setting up the thermostat:

1. Turn the seacock valve to the open position
2. If the water pump has a dedicated breaker, turn it on. Verify that water is being discharged overboard.

Instructions for the Thermostat

Cooling Cycle

1. Adjust the cooling temperature set point on the thermostat higher than the cabin temperature.
2. Slowly lower the thermostat's cooling set point until the set point is below the cabin temperature.
The blower, compressor and pump should be operating.
3. Close all doors and hatches.
4. Allow the unit to operate 10 minutes.

Chapter 5 - Winterizing the System

There are two scenarios for winterizing the system – the boat remains in the water or the boat is out of the water, in dry dock storage. Please follow the procedures described below for your situation.

Boat remains in the water

In water storage requires the use of a potable anti-freeze solution throughout the system's water supply and discharge lines. Be sure to follow all state, local and federal ordinances before discharging an anti-freeze solution overboard.

1. Close ball valve.
2. Disconnect water line at ball valve.
3. Insert line into a bucket of potable anti-freeze.
4. Run air conditioner until a solid stream of anti-freeze is being discharged overboard.
5. Reconnect water line at ball valve.

Boat is out of water in dry dock

With the boat out of the water:

1. Open the seacock to permit all the water to drain out of system via the thru-hull fitting.
2. Remove and empty the seawater strainer basin.
3. Loosen the screws on the pump head to allow the water to drain from the pump and from the water line between the pump and strainer.
4. Close the seacock.

When the boat is put back into the water in the spring:

1. Gradually open the seacock to allow water to fill the system to the level of the pump.
2. Tighten the pump face to achieve a seal.
3. Open the seacock valve completely.

SMB Air Conditioner

Chapter 6 – Troubleshooting

Troubleshooting Guide

PROBLEM/SYMPTOM	LIKELY CAUSE(S)	CORRECTION
The unit does not operate.	1. Power supply problem. 2. Tripped breaker/disconnect. 3. Thermostat	1. Check voltage at power supply. Check wiring to unit and external breakers or fuses. 2. Check circuit protection devices for continuity. 3. Setpoint may be too high if in cooling mode or too low if in heating mode; check unit and reset. Thermostat may be out of calibration or otherwise defective. Also check for loose connection(s).
Blower runs but compressor does not start.	1. Power supply problem. 2. Thermostat 3. Safety switches are tripping out unit. 4. Loose or defective wires. 5. Compressor 6. Refrigerant leakage or loss. 7. Control board	1. Check voltage at power supply. Voltage at unit must be + 10% of rated nameplate voltage. 2. Check the thermostat and unit for loose wires. Secure any loose connection. Check location of sensor and make sure that it does not touch the indoor coil. The sensor and/or thermostat should be replaced if defective. 3. Check for water flow. Check refrigerant charge. Check switches for loose wire connection, broken or burned contacts. 4. Tug on wires to see if they will separate from their connections. Replace terminals if they are loose or weak. 5. Check for electrical shorts, ground and open circuits. Replace compressor if defective. If electrical checks are ok, install a start capacitor and direct wire to see if the compressor will start. If this fails, remove and replace the compressor. 6. Locate leak(s), reclaim, repair, evacuate and recharge unit with refrigerant. 7. Verify that power is being provided from the control board. Replace control board if it is defective.
Compressor runs, but blower will not run.	1. Blower motor capacitor 2. Blower motor. 3. Power supply problem. 4. Control board	1. Verify capacitance, check for electrical shorts and ground. If defective, replace. 2. Check for electrical shorts, ground and open circuits. Replace blower motor if it is defective. 3. Check voltage at power supply. Voltage at unit must be + 10% of rated nameplate voltage. 4. Verify that power is being provided from the control board. Replace control board if it is defective.

SMB Air Conditioner

PROBLEM/SYMPTOM	LIKELY CAUSE(S)	CORRECTION
Unit provides insufficient cooling.	<ol style="list-style-type: none"> 1. Restriction in water system. 2. Water pump. 3. Air filter. 4. Indoor coil. 5. Ice on indoor coil. 6. Unit is undersized 7. Low refrigerant 	<ol style="list-style-type: none"> 1. Strainer or thru-hull fitting are clogged. Clean and check for water flow. Make sure seacock (ball valve) is open. 2. Check for electrical shorts, ground and open circuits. Replace water pump if it is defective. Replace water pump if it is undersized. 3. Clean or replace the air filter if it is dirty. 4. The indoor coil may require cleaning if the unit was operated without a filter. 5. Thermostat setting is too low. Shut down unit until ice has melted and restart at a higher temperature setting. 6. Check if the unit is undersized for the load. Replace with larger unit or add additional unit(s) if necessary. 7. Add refrigerant
Noise operation.	<ol style="list-style-type: none"> 1. Copper tubing is vibrating. 2. Indoor blower assembly. 3. Loose cabinet or components. 4. Improper unit installation. 	<ol style="list-style-type: none"> 1. Adjust by bending slightly to a more stable position. Separate any tubing that is making contact with other tubing or components. 2. If blower wheel is hitting housing, adjust the wheel position in the housing. Replace blower motor or assembly if the bearing(s) are defective. 3. Check and tighten loose screws. 4. Make sure unit is level and secure to deck.
Water is leaking from unit.	<ol style="list-style-type: none"> 1. Condensate pan. 2. Condensate drain line or pump. 3. Loose fittings or connections. 	<ol style="list-style-type: none"> 1. Check for leaks and repair as required. 2. Check for leaks and repair as required. 3. Tighten fittings and connections. Check the condensate drain line for leaks.
Electrical shock at unit.	<ol style="list-style-type: none"> 1. Electrical component is shorted to ground. 	<ol style="list-style-type: none"> 1. Check control board, blower motor, compressor and pumps with an ohmmeter or high potential tester. Determine what is grounded and replace or rewire. 2. Line trip is too sensitive

SMB Air Conditioner

Chapter 7 – Wiring Diagram

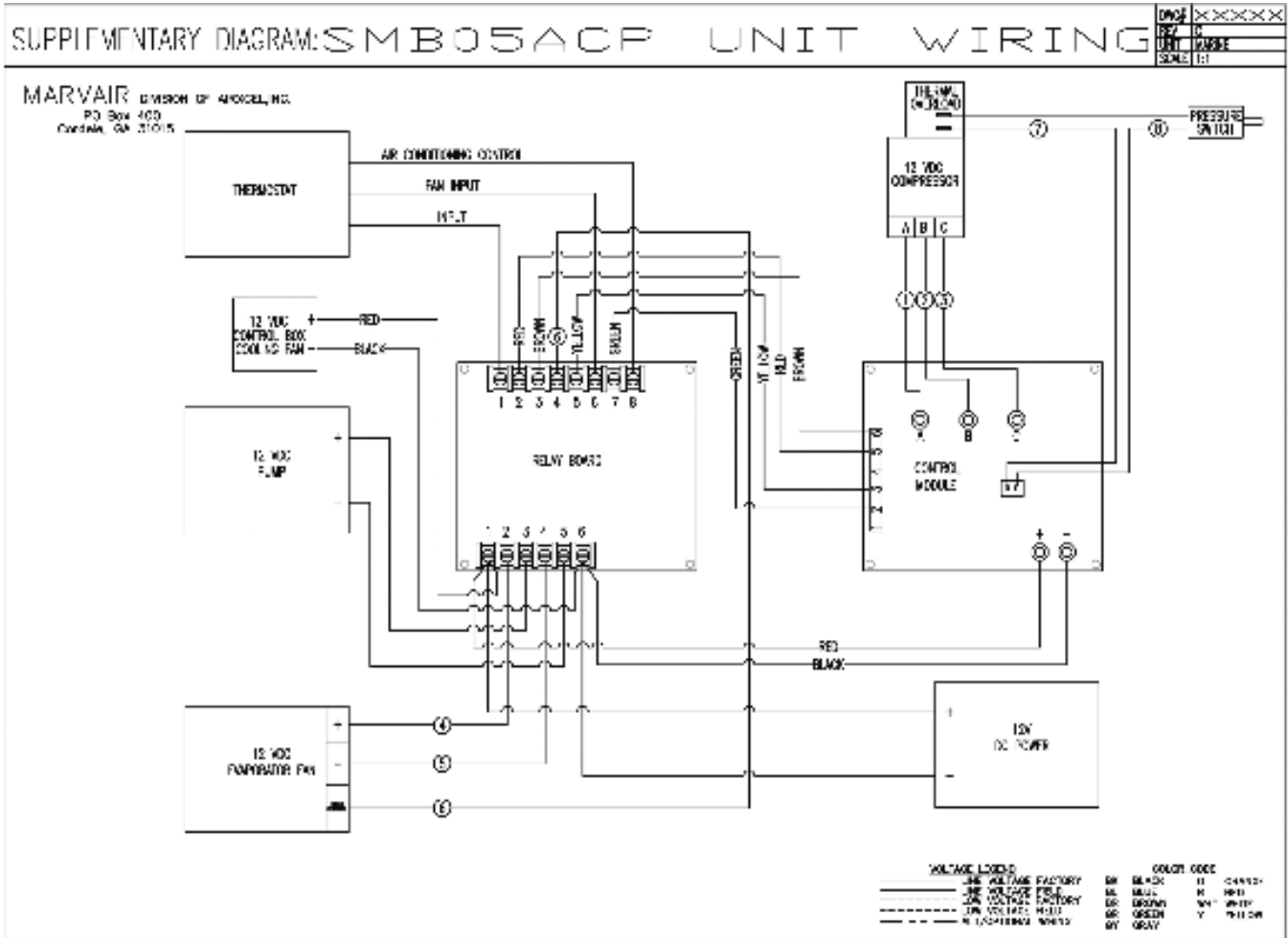

SMB Air Conditioner

Chapter 8 – Spare Parts List

Recommended Spare Parts	Marvair Part Number
Compressor	10343
Control Module	01627
Evaporator Coil	60127
Blower Assembly	30067
Control Board	50196
Condenser (water coil)	60194
High Pressure Switch, Manual Reset (400 psig)	70339
Cap Tube/Strainer Assembly	20419
Filter	91916
Cooling Fan	01629
Low Voltage Harness Assembly	01678
VDC Power Harness Assembly	01679
Guard for Cooling Fan	01628

Marvair® Marine Self-Contained and Split Systems Warranty

Parts

If any part of your Marvair unit fails because of a manufacturing defect within twenty-four months from the date of purchase of a new boat or within twenty-four months from the date of installation of the air conditioner, but not to exceed thirty-six from the date of manufacture by Marvair, Marvair will furnish without charge, EXW Cordele, Georgia, the required replacement part.

Labor

If any part of your Marvair reverse cycle air conditioner or air conditioner fails because of a manufacturing defect within twenty-four months from the date of purchase of a new boat or within twenty-four months from the date of installation of the air conditioner, but not to exceed thirty-six from the date of manufacture by Marvair, Marvair will pay for the related service labor to replace the failed part according to the Marvair Flat Rate Schedule currently in effect. The owner must provide proof of the date of the purchase of the boat or date of installation of the Marvair unit. The owner's registration card filed with Marvair, the invoice for the purchase of the vessel, an invoice for the installation of the unit, or similar documents are examples of proof of the date.

When service is required, it must be performed during normal working hours (8:00 a.m. to 5:00 p.m.) Monday through Friday and must be performed by Marvair personnel or their designated Service Representative.

The responsibility of the Owner of the Equipment includes the following:

1. To operate the equipment according to the manufacturer's instructions.
2. To provide easy accessibility for service.
3. To check and reset circuit breaker(s) and disconnect before calling for service. (Circuit breaker(s) may be in the main service panel.)
4. To keep the unit clean and free of dirt.
5. To clean and/or replace the filter as required. (The filter may be located in the return air filter grille or in front of the evaporator coil.)
6. To keep the evaporator coil clean and the condenser coil free of sediment or scale.
7. To pay the charges incurred when any of the above have not been done.
8. To pay for repair or replacement of any material or part other than those within the Marvair unit or thermostat itself.
9. To check any fuses on the circuit board and replace as required.

The owner of the product may ship the allegedly defective or malfunctioning product or part to Marvair, at such owner's expense, and Marvair will diagnose the defect and, if the defect is covered under this warranty, Marvair will honor its warranty and furnish the required replacement part. All costs for shipment and risk of loss during shipment of the product or part to Marvair and back to the owner shall be the responsibility and liability of the owner. Upon request by an owner, Marvair may arrange for remote diagnosis and repair of the allegedly defective or malfunctioning product or part.

An owner requesting performance under this Warranty shall provide reasonable access to the allegedly defective or malfunctioning product to Marvair and its authorized agents and employees.

SMB Air Conditioner

This warranty does not cover damage caused by improper installation including any refrigerant leaks in the tubing and fittings between the evaporator and condenser sections on split systems; misuse of equipment; negligent servicing; damage due to use of the product for purposes other than those for which it was designed; damage caused by natural disasters, power surges, lightning and submersion; damage caused by unauthorized modifications; and damage caused by improper wiring or power supply to the air conditioner including operating the unit with an undersized generator.

THIS WARRANTY AND SERVICE POLICY CONSTITUTE THE EXCLUSIVE REMEDY OF ANY PURCHASER OF A MARVAIR REVERSE CYCLE AIR CONDITIONER AND IS IN LIEU OF ALL OTHER WARRANTIES, EXPRESSED OR IMPLIED, INCLUDING, WITHOUT LIMITATION, ANY IMPLIED WARRANTY OF MERCHANTABILITY OR FITNESS FOR USE, TO THE FULLEST EXTENT PERMITTED BY LAW. IN NO EVENT SHALL ANY IMPLIED WARRANTY OF MERCHANTABILITY OR FITNESS FOR USE EXCEED THE TERMS OF THE APPLICABLE WARRANTY STATED ABOVE AND MARVAIR SHALL HAVE NO OTHER OBLIGATION OR LIABILITY. IN NO EVENT SHALL MARVAIR BE LIABLE FOR INCIDENTAL OR CONSEQUENTIAL DAMAGES OR MONETARY DAMAGES.

THIS WARRANTY GIVES YOU SPECIFIC LEGAL RIGHTS, AND YOU MAY ALSO HAVE OTHER RIGHTS WHICH VARY FROM STATE-TO-STATE. Some states do not allow limitations or exclusions, so the above limitations and exclusions may not apply to you.

5/09 Rev. 5